

Fast Flow 4" Ductile Iron Twin Motor Centrifugal Hydraulic Submersible Pump



USER MANUAL Safety, Operation and Maintenance



CE  II 2 G
Ex h Gb T6

FF-4D-TM CENTRIFUGAL SUBMERSIBLE HYDRAULIC PUMP

Operation and Maintenance Manual

Manual: FF-4D-TM	Language: English	Revision: 8
------------------	-------------------	-------------

Fast Flow Pumps LLC
9700 Highway 63
Moss Point, MS 39562
Phone (228) 475-2468 • Web fastflowpump.com

TABLE OF CONTENTS

Safety Information	4
Description	5
Technical Data.....	5
Patent Information	5
Installation	6
Unpacking and Hose Installation	6
Hydraulic Power Unit Installation & Pump Connection.....	7
Hydraulic Connections.....	8
Pump Testing Procedures	9
Shutdown and Disassembly	10
Exploded View Diagrams.....	11
Major Pump Parts	11
Torque Spec Sheet	12
Impeller Removal and Replacement.....	13
Troubleshooting.....	14
Warranty	15

Safety Precautions

- Read and familiarize yourself with both the FF-4D-TM Manual and the HPU's manual before attempting to operate this pump. Pump service applications are seldom identical, please call Fast Flow Pumps at (228) 475-2468 if you have any questions about your specific application.
- Always wear proper safety equipment while operating this pump. This includes safety goggles, head protection, and safety shoes.
- Inspect all hose connections, ensure that they are properly tightened, inspect screw together hydraulic couplings are fully tightened.
- Inspect the pump for any loose frame bolts or damage. Make sure the pump is fully assembled before operation, failure to do so may result in injury or damage to the pump.
- Maintenance and service MUST only be performed by properly trained personnel. Failure to do so can cause personal injury or damage to this pump.
- Make sure this pump is compatible with your pumping application, do not use this pump with incompatible applications or exceed the limits of this pump.
- Operate below 160^of. Slurry solids must be flowable.
- When lifting this pump, your lifting equipment must be rated for at least 5 times the weight of the pump, discharge hose, and weight of the any fluids in the pump.
- Make sure pump impeller rotation is correct, it should be counterclockwise, spinning towards pump discharge. See diagram on page 6 for more information.
- DO NOT place any hands inside the pump while pump is in operation.
- DO NOT wear loose clothing while operating this pump. Loose equipment or clothing can become trapped inside of moving parts and cause serious injury.
- DO NOT operate this pump without proper training or instructor supervision.
- DO NOT lift any submersible pump by the hydraulic lines.
- DO NOT point hose at bystanders.
- Always disconnect hydraulic lines from pump before servicing.

Local and Application Specific Safety Notes

Description

This operation and maintenance manual applies to the Fast Flow Pump model FF-4D-TM Centrifugal pump system, made up of two major components—the pump head manufactured by Fast Flow Pumps and the Hydraulic Motors mounted on the Pump Head. In order to use this pump system you will also require supply and return hydraulic hose and an external power source.

The pump head is a heavy-duty impeller blade design that will handle varied and severe service use that many other systems cannot. The unique pump design utilizes suction from both sides of the impeller thus eliminating thrust-load problems associated with centrifugal pumps. The FF pump system is ideal for abrasive waste pumping, enviro pumping, barge cleaning, dewatering, and wash down applications or the pumping of any slurred solids. Please note that any use of this pump outside of approved applications can cause damage to the unit. Please read this manual thoroughly before using this pump system.



Fast Facts	
Weight:	157lb (71kg)
Max Water Flow:	1200 GPM (272m ³ /h)
Max Vertical Head:	230 Feet (70m)
Operating PSI:	2250-3500 PSI (155-241 Bar)
Hydraulic Flow:	8 to 32 GPM (30-121 lpm)
Power Source:	Hydraulic Driven
Material:	Hardened Ductile
Discharge:	4" Male Cam Lock
Dimensions:	36"x16"x22" (91cm x 40cm x 55cm)
Hydraulic Oil:	AW-32 or AW-46

Patent Information

Fast Flow Pumps are covered by U.S. Patent No.6,942,448, No. 7,442,003, No. 8,152,443, No. 10,138,891 and other USPTO Patents Pending, European Union Patent, and protected internationally under the Patent Cooperation Treaty.

Installation

Before operating this pump system, please go through the following steps to ensure safe and efficient operation.

Important!

- Read and familiarize yourself with the manuals for the pump system as well as any manuals for external hardware, such as the power source.
- Inspect the pump head and frame for any damage such as loose bolts, cracks, dents, foreign objects, or damaged threads.
- Check for and tighten loose attachments, make sure couplings are properly installed and any hydraulic hoses are properly installed. Double check discharge camlock fitting connections. Ensure hydraulic couplings are fully tightened.
- Ensure correct pump rotation, pump impeller rotation should be counterclockwise spinning towards discharge.

Unpacking

- Ensure you are working on a level and dry surface with adequate space and assistance to remove the components from shipping and packing materials.
- Recycle shipping and packing materials as appropriate.
- Consult the separate manuals provided by the motor, hydraulic power unit, and hydraulic hose manufacturers as necessary.
- Ensure that all packing material has been removed from the pump housing and that the impeller rotates freely.
- Ensure the hydraulic motor and hose couplings are free of blockage, have not been damaged, and properly match.
- Contact Fast Flow Pumps or an approved service provider if any system component appears to be damaged, defective, or incomplete.

Hose Installation

- Connect the hoses from the power source—connect the return hose first, when turning off the unit the return hose should be disconnected last. This minimizes trapped pressure within the motor.
- Fully tighten the screw together couplings.
- Ensure the flow is in the proper direction. Hydraulic Flow should be counterclockwise towards discharge.

Fluid Power System | Hydraulic Power Unit (HPU)

- Follow any warning stickers and instructional stickers on the HPU, as well as reading the manual.
- Ensure the HPU has a flow of 4-32 GPM (15-121 LPM) @ 2000-3000 PSI (155-206 Bar) and make sure the system operating pressure is set between 1500 PSI to 3000PSI. (103-206 Bar) The normal pressure for most applications is 2800 PSI.
- Ensure that the system operating pressure does not exceed 3300 PSI (227 Bar)
- Check pump inlets, make sure there is no debris inside.
- Always disconnect hydraulic lines before servicing pump.

Make sure you follow any additional directions found in the manual for the power unit. Failure to do so may result in equipment failure or personal damage. These instructions may not be applicable to non-FFP Power Units.

Connecting the Pump

- Connect hoses from HPU to pump, using the below diagram as reference.
- Turn on the power unit and perform a Dry Run test, described on the next page.
- Connect lifting shackle to the FF Lifting Ring, and use it to lower the pump into the fluids being pumped. Handling the pump by the hydraulic hoses/couplings can cause equipment damage.

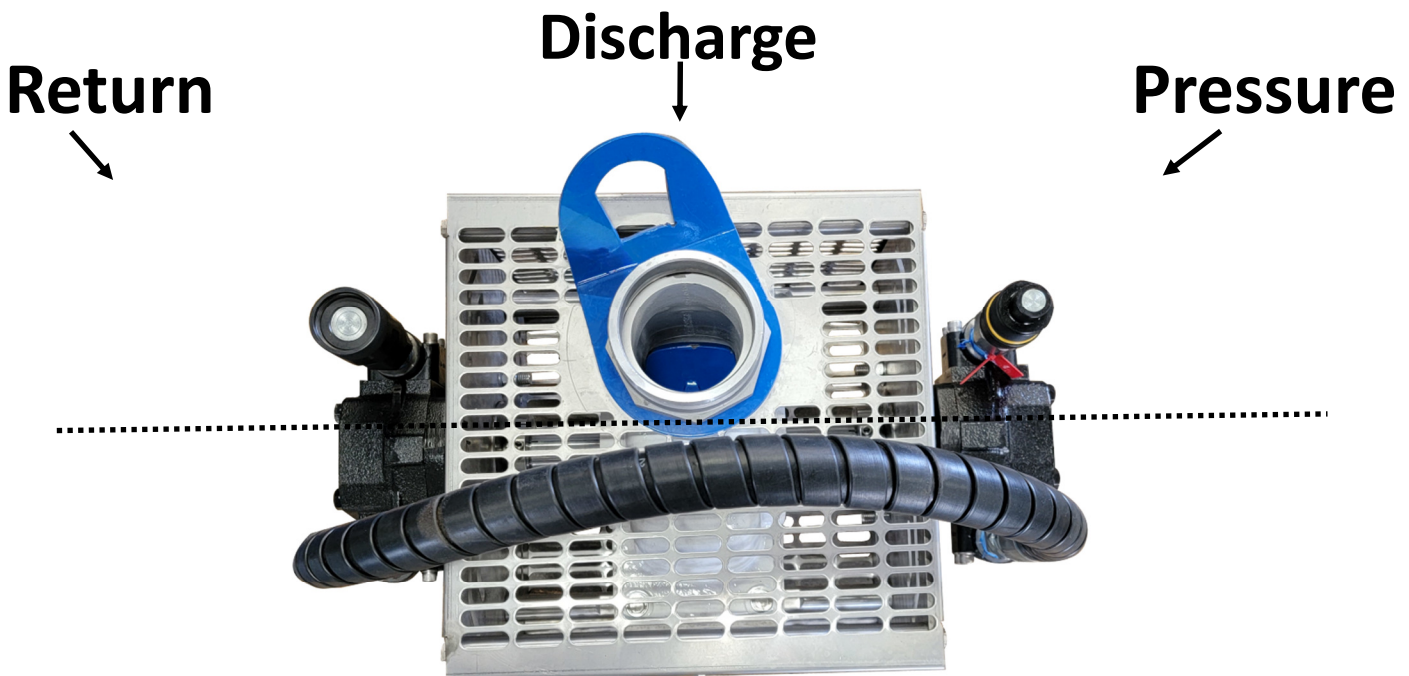

Notice: Couplings align with discharge.

Hydraulic Connections

1. Clean the mating surface of the couplings to avoid contaminating the circuit.
2. Pull the connection sleeve of the female coupling forward
3. Align the female and male coupling holding the connection sleeve and thread together and turning the sleeve.
4. Keep couplers aligned during connection process. Do not push the couplings together.
5. Screw the connecting sleeve of the female until metal surface contact with the male coupling is complete, the yellow O-ring should be concealed.
6. To disconnect turn the sleeve from the contact position using a wrench, then unscrew making sure the couplings stay aligned through the entire process.

Incorrect Coupling—O-Ring Exposed



Correct Coupling— Metal to Metal Contact



Metal to Metal Contact

Seal Area

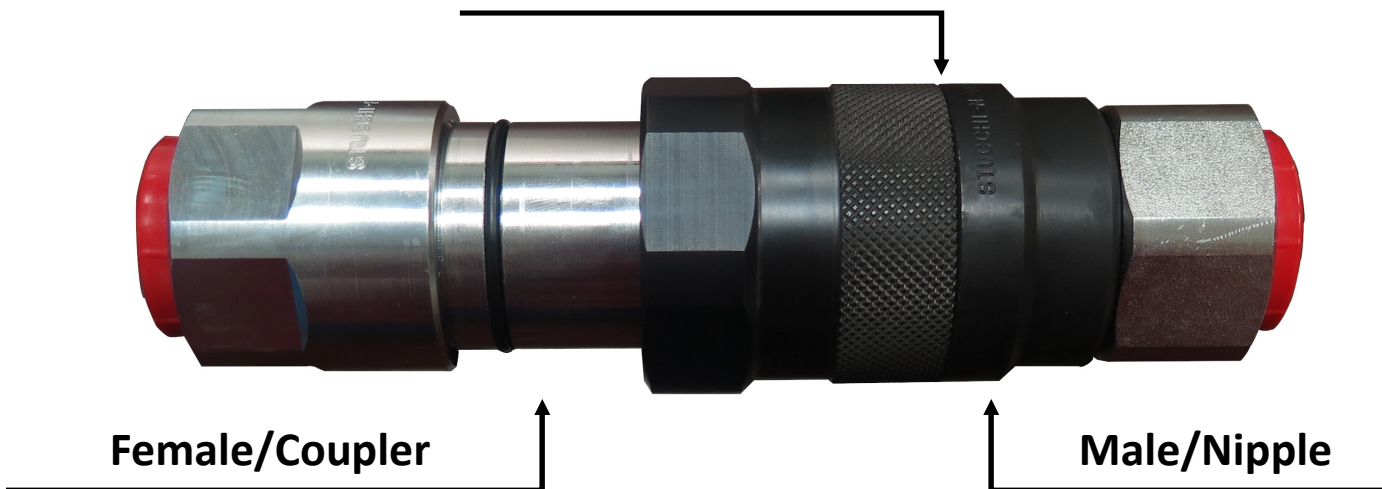

Warning! Do not attempt to connect hoses with the engines and pump running.

Pump System Test Procedures

Dry Run Spin Test

The FF-4D-TM is capable of Running Dry for extended periods of time, and it is best practice to perform a run dry test before using the pump. To perform this test, first double check that all hydraulic couplings are fully tightened, then connect the hydraulic system and run the FF-4D-TM pump dry with varying speeds for 1-2 minutes. The pump has no internal friction. At lower rpms the pump head can be left running without damage.

Correct Rotation of Pump

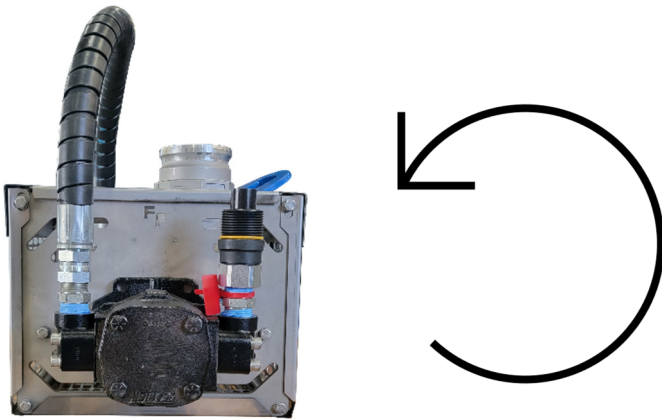

Pump should rotate counter-clockwise towards Discharge

HPU Start-Up Checklist

WARNING: These instructions may not apply to non-FFP Power Units or HPUs, please read all technical literature associated with your power unit before running the system.

Always dry run spin test pump before placing pump into pit. Do not skip this test. That will leak test the entire hydraulic system, verify impeller direction, and function test the hydraulic motor.

All hydraulic couplings must be fully tightened.

Check hydraulic tank oil level

Check hydraulic filter and clear fluid color

Check engine oil and fuel levels

Leak check hydraulic hose and couplings

Shutdown and Disassembly

Shut Down

- Slowly shut down the power unit, starting/stopping fluid flow suddenly can cause damage to the pump and motor seals.

In case of Emergency, you can use the manual shutdown on the hydraulic power unit.

Disassembly

- Ensure all moving parts have come to a complete stop.
- Shut down the HPU and turn key switch to the off position.
- Place pump head on flat surface.
- Ensure that there is no trapped or residual pressure in the system.
- Disconnect hydraulic supply/return hoses.
- Clean the hydraulic submersible pump after each use.
- Avoid hydraulic fluid contamination, all lines and couplings should not be open to atmosphere.

Fast Flow Pumps - FF 4" Ductile Iron Twin Motor Pump Major Pump Parts

Fast Flow
Pump Part Number
FF-4D-TM-SS

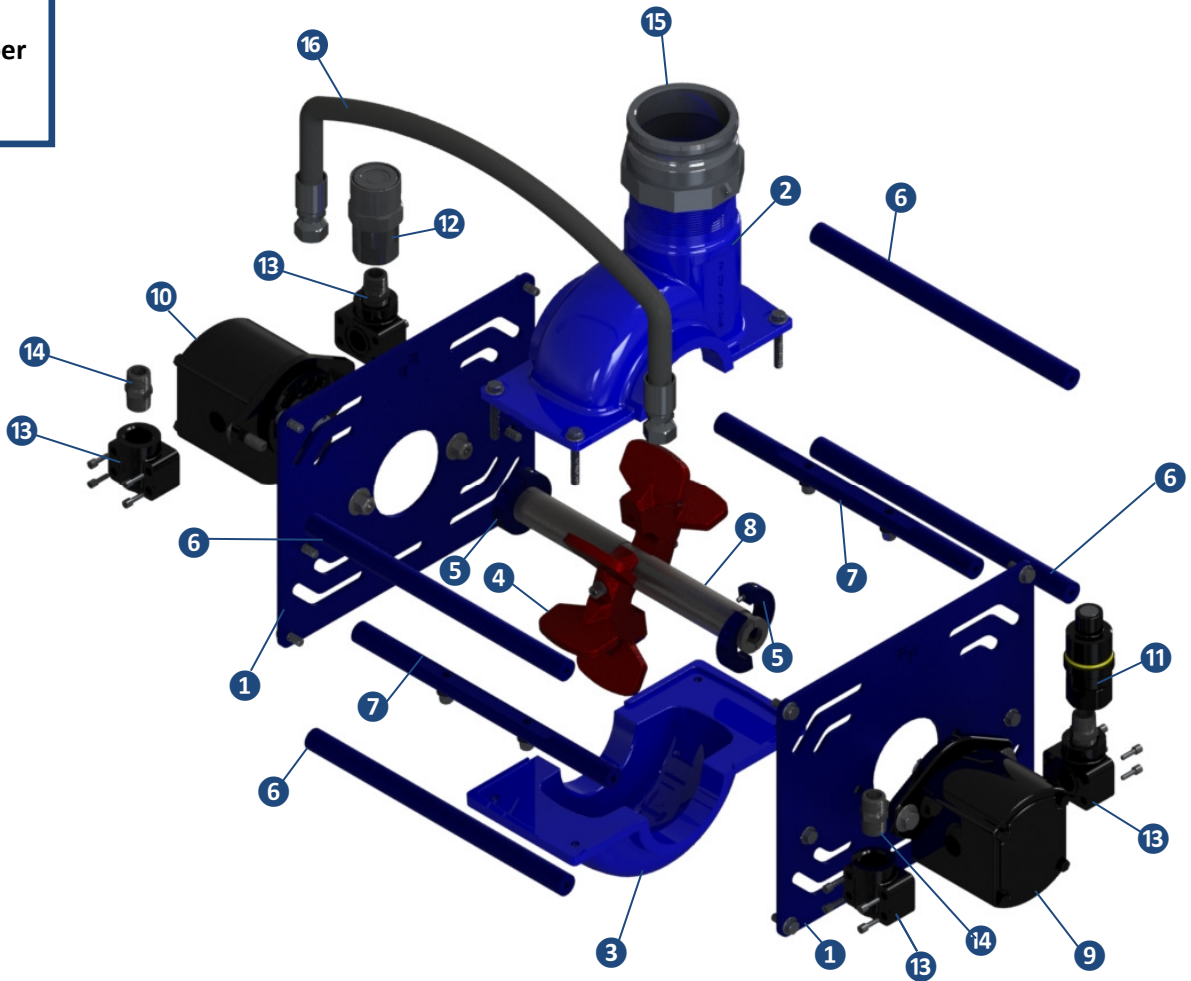

Major Pump Parts

Description	Part No.	Qty	Description	Part No.	Qty
1. Motor Plate	MP-4D-SS	2	12. 1" Female VEP Hyd Coupling HD	HPU089	1
2. Upper Volute Casting	VU-4D	1	13. Code 61 Flange	ADP293	4
3. Lower Volute Casting	VL-4D	1	14. Male Pipe Adapter	ADP216	4
4. Impeller	IM-4D-15	1	15. Camlock	CAM001	1
5. Drive Shaft Collar	SC-4D-SS	2	16. Bridle Hose	4D-TM-HB	1
6. Frame Bar	FB-4D-SS	4	Not Shown		
7. Mount Bar	MB-4D-SS	2	16. Impeller Keystock	IK-4D-SS	1
8. Drive Shaft	CS-4DTM-SS	1	17. Serial Tag	TAG001	1
9. Driving Motor	MTR009	1	19. Keystock	MK-4D-SS	1
10. Flushing Motor	MTR010	1	20. Red Pressure Tag	6-CRE	1
11. 1" Male VEP Hydraulic Coupling	HPU087	1	21. Lifting Ring	LR4	1

Fast Flow Pumps - FF 4" Ductile Iron Twin Motor Pump" Torque Specs

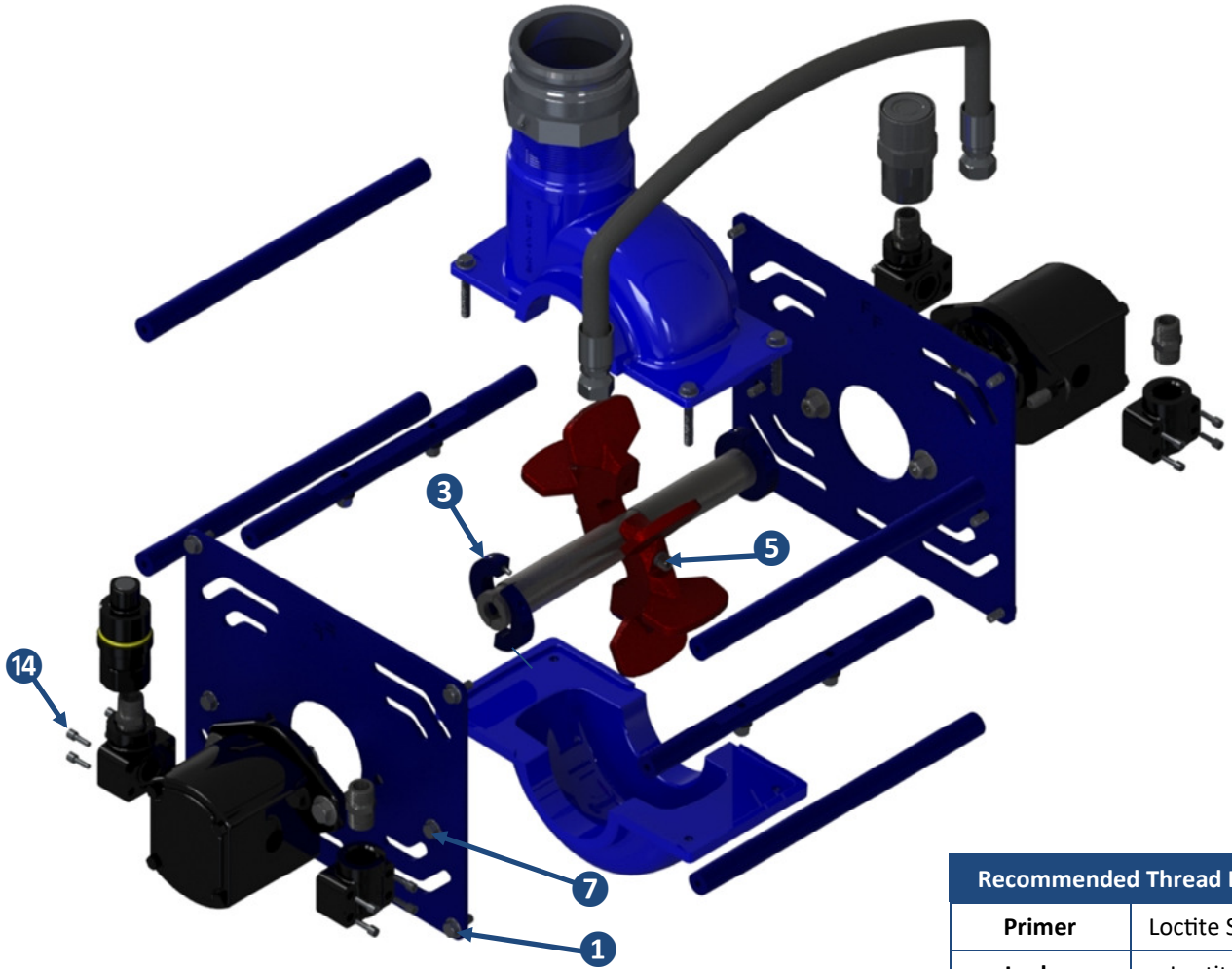

Recommended Thread Locker	
Primer	Loctite SF 7649
Locker	Loctite 242

Hardware List

Description	Part No.	Qty	Torque Specs	Anti-Seize	Loctite	Primer
1. 3/8"-16 x 1" (SS) HCS [Hex Head Bolt]	HDW113	12	17 ft-lb/23 Nm		✓	✓
2. 3/8" x 7/8" O.D. Flatwasher (SS)	HDW065	8	Not Applicable			
3. 3/8"-16 Nylon Locknut (SS)	HDW077	4	Not Applicable			
4. 3/8"-16 x 2 1/4" (SS) HCS [Hex Head Bolt]	HDW023	4	Not Applicable			
5. 3/8" Nordlock Washers	HDW063	14	Not Applicable			
6. 1/2"-13 x 2" (SS) HCS [Hex Head Bolt]	HDW122	4	43 ft-lb/50 Nm	✓		
7. 1/2" x 1 1/4" O.D. Flatwasher (SS)	HDW055	8	Not Applicable			
8. 1/2"-13 Nylon Locknut (SS)	HDW078	4	Not Applicable			
9. 1/4"-28 x 3/4" SHCS Bolt	HDW127	4	Not Applicable			
11. 5/16"-16 x 1" SHCS (SS)	HDW100	4				
12. 3/8" - 16 x 2 1/2" SHCS (SS)	HDW125	2	Not Applicable			
13. 3/8" Lockwasher (SS)	HDW064	18	Not Applicable			
14. 3/8"-16 x 2-1/4" Socket Head Cap (SS)	HDW110	16	Not Applicable			

ATEX Information

~ Notice ~

This pump is ATEX Certified for use in Explosive Atmospheres

Maximum operating temperature is 160°F.

Any part replacement must be done with OEM parts – no exceptions

Any deviation voids the warranty and invalidates the ATEX Certification

~ Warning ~







This pump is ATEX Certified for use in Explosive Atmospheres

It is absolutely imperative when this pump is in operation that there be no contact between the impeller and the pump housing. Any contact, even in the slightest, may generate sparks resulting in an explosion!

The pump comes properly aligned and tested from the factory. When repairing the pump, the included step-by-step alignment process must be followed! Any deviation voids the warranty and invalidates the ATEX Certification.

All ATEX pumps will have one of the following ATEX Marks depending upon how the pump is used.

Fast Flow Pumps ATEX Markings Explanation

ATEX Marking	Explanation
  I M2 T160°F	Mining equipment, Category 2, Max operating temperature of 160°F, for de-energized use
  II 2 G D T160°F	Non-mining equipment, Category 2 (zone 1 & 21), Max operating temperature of 160°F, for gases & dusts
  II 3 G D T160°F	Non-mining equipment, Category 3 (zone 2 & 22), Max operating temperature of 160°F, for gases & dusts

ATEX '99 Zone		ATEX 2014 Category	Protection Level	Description
Gases & Vapors	Dusts			
0	20	1	Very High	Explosive atmospheres are present continually or for long periods or frequently
1	21	2	High	Explosive atmospheres are likely to occur under normal operations, occasionally
2	22	3	Normal	Explosive atmospheres are not expected to occur under normal operations. Where they do occur, it will be for a short period only.

- FF-4DTM-SS Pump Assembly Procedure -

Parts Layout –

Begin by identifying all applicable pump parts.

- Driving Motor
- Hydraulic Motor Adapters
- Hose Bridle
- Coupled Shaft
- Pump Hardware Kit
- Camlock
- Lower Volute
- Lifting Ring
- Loctite 242
- Flushing Motor
- Hydraulic QD Couplings
- Impeller
- Frame Parts
- Shaft Collars
- Upper Volute
- Debris Cage
- Motor and Impeller ¼” Keyways
- Loctite Primer SF 7649

Assembly Preparation –

Once parts have been identified then the components can be prepared for assembly.

1. Unbolt impeller then separate keyed side from non-keyed side.
2. Unbolt Shaft Collar then separate the two pieces.
3. Tape hydraulic adapters with Teflon Thread Tape.
4. Fasten ADP216 Male Pipe Adapter to ADP293 Flange Block securely.
5. Fasten HPU087 QD Coupling on (1) ADP216 Adapter securely.
6. Fasten HPU089 QD Coupling on (1) ADP216 Adapter securely.
7. Remove plastic dust cap from Flushing and Driving Motor Shafts.
8. Remove Flushing Motor and Driving Motor ¼” Keystock.
9. Apply Loctite to Flushing Motor and Driving Motor ¼” Keyway Slot.
10. Install Flushing Motor and Driving Motor ¼” Keystock.
11. Apply Loctite to Coupled Shaft Impeller ¼” Keyway Slot.
12. Install Impeller ¼” Keystock to Coupled Shaft Keyway Slot.

Motor Assembly –

The first step in the procedure starts with the motor assembly.

13. Use HDW110 hardware for Steps 14-17 and apply Loctite to bolt threads before securing. (17ft-lb)
14. Fasten (1) ADP293 Flange Block without QD Coupling to inlet side of Flushing Motor securely.
15. Fasten (1) ADP293 Flange Block without QD Coupling to outlet side of Driving Motor securely.
16. Fasten (1) ADP293 Flange Block with HPU087 QD Coupling to inlet side of Driving Motor securely.
17. Fasten (1) ADP293 Flange Block with HPU087 QD Coupling to outlet side of Flushing Motor securely.
18. Use HDW122, HDW055, and HDW078 hardware for Steps 7-9.
19. Mount Driving Motor to (1) Pump Motor Plate by bolting together through SAE Boss Cut Out.
20. Mount Flushing Motor to (1) Pump Motor Plate by bolting together through SAE Boss Cut Out.

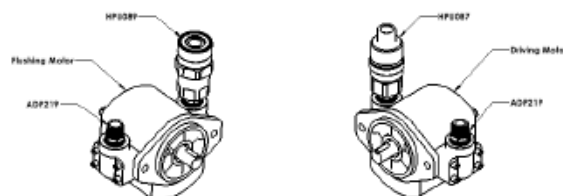

Frame Assembly Part One –

The following steps in the procedure begins the first part of the frame assembly.

21. Use HDW113 and HDW063 hardware for Steps 22-24 and apply Loctite to bolt threads before securing.
22. Fasten (1) Frame Bar to bottom right bolt hole of Driving Motor Plate securely. (17 ft-lb)
23. Fasten (1) Frame Bar to bottom left bolt hole of Driving Motor Plate securely. (17 ft-lb)
24. Fasten (1) Frame Bar to top right bolt hole of Driving Motor Plate securely. (17 ft-lb)

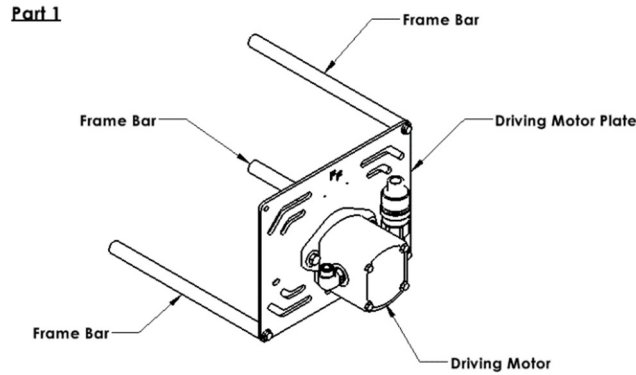

25. Slide Pump Coupled Shaft onto Flushing Motor Shaft.

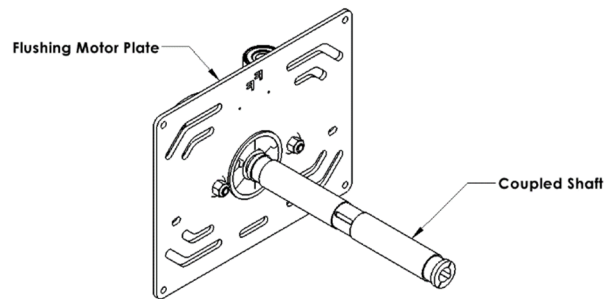

26. Use HDW113 and HDW063 hardware for Steps 28-29 and apply Loctite to bolt threads before securing.
27. Slide opposing Pump Coupled Shaft end onto Driving Motor Shaft.
28. Fasten mounted Frame Bars from Driving Motor Plate to Flushing Motor Plate loosely.
29. Fasten (1) Mount Bar to middle bolt hole between Motor Plates loosely.

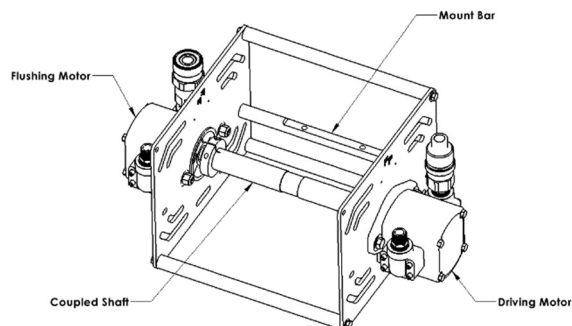

Frame Assembly Part Two –

The following steps in the procedure conclude with the second part of the frame assembly.

30. Place Lower Volute housing on top of mount bar with the shorter flange facing towards pump front.
31. Place mount bar underneath Lower Volute housing bolt holes with shorter flange correctly on the Mount Bar flat side and lift.
32. Once lifted fasten mount bar to Motor Plate with hardware loosely after applying Loctite. (17 ft-lb)
33. At this step the Lower Volute is rested on top of both Mount Bars loosely fitted to Motor Plates.
34. The pump assembly now has the Coupled Shaft and Lower Volute in position for the impeller assembly.

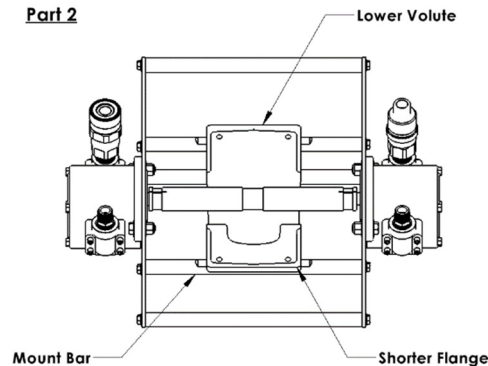

Impeller Assembly –

The impeller assembly consist of installing and centering the Impeller, Coupled Shaft, and Shaft Collars.

35. Use HDW125 and HDW063 hardware for Steps 36-39 and apply Loctite to bolt threads before securing.
36. Place non-keyed impeller side into Lower Volute cavity positioned underneath Coupled Shaft.
37. Place keyed impeller side around Coupled Shaft Step-Down securely on shaft ¼” keystone.
38. Install Impeller hardware through mounting hole loosely on keyed side then rotate to opposing side.
39. Install Impeller hardware through mounting hole loosely on non-keyed side.
40. Use HDW127 hardware for Step 41-42 and apply Loctite to bolt threads before securing.
41. Place each side of the Shaft Collar around the milled end of the Coupled Shaft then repeat on opposite side. Be sure to align the split of the Shaft Collar with the relief of the Coupled Shaft milled end.
42. Fasten Shaft Collar hardware loosely and center inside of milled end Step-Down.

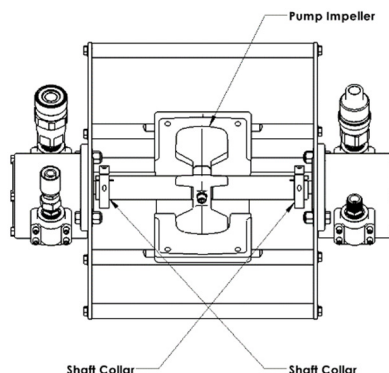

43. Using Feeler Gauges evenly space Coupled Shaft ends from Motor Face Plate.

44. Using Feeler Gauges evenly space Impeller sides from Coupled Shaft Impeller Step-Down.
45. Using Feeler Gauges evenly space Impeller blades to Lower Volute inside surface sides.
46. Using Feeler Gauges evenly space impeller blade tips to Lower Volute inside surface ends by sliding Mount Bars back and forth to help center Impeller position.

Impeller Assembly –

The impeller assembly consist of installing and centering the Impeller, Coupled Shaft, and Shaft Collars.

47. Use Lower Volute hardware to hold Lower Volute in position while centering Impeller.
48. Center Impeller to Coupled Shaft Step-Down then secure Impeller hardware.
49. Once the Impeller has been centered the Mount Bars can be securely fastened.
50. Check Impeller center position after securing Mount Bars.
51. Check Coupled Shaft center position then secure Shaft Collar hardware.
52. Check Coupled Shaft center position after securing Shaft Collar hardware.
53. All hardware should be securely fastened, except for the Lower Volute housing at this Step.

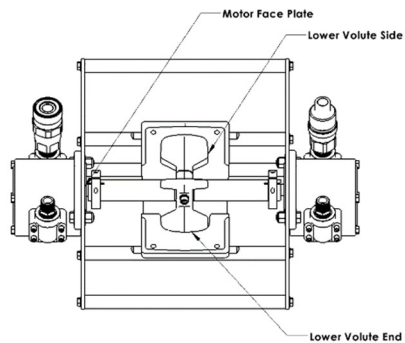

Housing Assembly –

The pump housing assembly consist of securing the Top Volute to the Lower Volute around the Impeller.

54. Remove Lower Volute hardware used for positioning purposes.
55. Place Top Volute onto Lower Volute around Impeller with matching short flange bolt holes.
56. Fasten Top Volute to Lower Volute using previously described hardware loosely.
57. Check Impeller rotation has no interference then fasten hardware securely.
58. Install last remaining Frame Bar with previously described hardware then fasten securely.

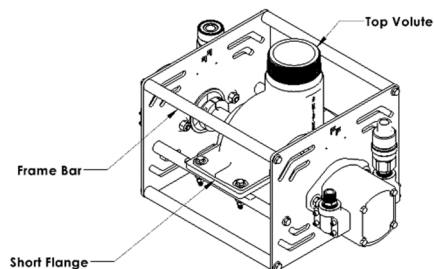

59. Next check to ensure all hardware for motors, frame, housing, and collars have been fastened securely.
60. Check Impeller rotation once again to ensure no interferences have developed while securing hardware.

61. At this Step the Coupled Shaft and Impeller should freely rotate by hand with no binding issues.
62. If required, the Debris Cage should be installed at this Step in the Pump Assembly Procedure.

Hose Bridle Assembly –

The Hose Bridle Assembly is the final process in the Pump Assembly Procedure.

63. Install Hose Bridle by fastening the 16FJX Hose Couplings to the 16MP Adapters located on the pump motors by hand.
64. Once the Hose Bridle is fitted and fastened to the motor adapters securely tighten using two wrenches of adequate size.
65. When tightening Female JIC Fittings only turn one half turn or three quarters turn or until sealed.
66. Once the Hose Bridle has been installed the Camlock should be secured to the Top Volute.
67. Start by brushing Anti-Seize Corrosion Inhibitor into the threads of the Top Volute.
68. After applying Anti-Seize then fasten camlock securely to Top Volute threads by hand.

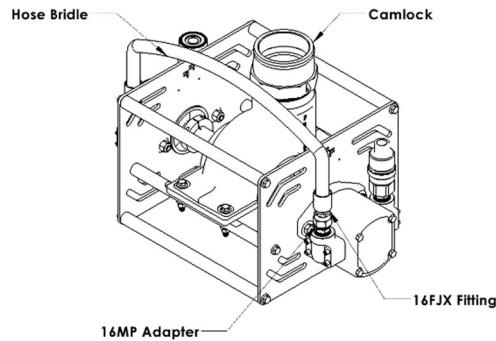

This concludes the final Steps in the Pump Assembly Procedure.

Troubleshooting

Problem	Possible Causes	Resolutions
Pump will not Turn	<ol style="list-style-type: none"> 1. No hydraulic fluid or pressure. 2. Bad hydraulic couplers or not screwed together properly 3. Impeller jammed 4. Damaged gear motor 5. Impeller shaft to hydraulic motor coupling problems. 	<ol style="list-style-type: none"> 1. Turn on power unit and test that appropriate flow and pressure is available with flow gauge and pressure meter. 2. Connect all supply and return hydraulic hoses together, make sure all connections are fully tightened. Flow hydraulic fluid without pump attached. 3. Remove any debris from the volute. This includes rope, wire, rags, and nylon bags. 4. Replace gear motor 5. Check keyway for damage.
Poor Performance or Low Flow Rate	<ol style="list-style-type: none"> 1. Hydraulic flow reversed. 2. Improper hydraulic fluid flow. 3. Pump inlet jammed. 4. Discharge hose is too small 5. Impeller Damage 6. Contaminated Hydraulic Fluid 7. Hydraulic motor worn out. 	<ol style="list-style-type: none"> 1. Make sure hoses are connected properly, see Pump Diagram on page 5. 2. Turn on power unit and test that appropriate flow and pressure is available with flow gauge and pressure meter. 3. Clean the inlet and make sure any debris is removed. Remove hydraulic lines before servicing. 4. Use a bigger discharge hose to increase flow rate 5. Replace Impeller, consider using debris cage if pit contains rocks. 6. Drain bad oil out of hydraulic system and clean out the tank with mineral spirits and refill with new oil. 7. Inspect motor wall internals, if okay,
Hydraulic Back Pressure	<ol style="list-style-type: none"> 1. Return line not fully open 	<ol style="list-style-type: none"> 1. Check and tighten all connections. 2. Increase size of return hydraulic hose

Warranty Information

Warranty for Submersible Pumps, Fast Flow Pumps warrants to the original purchaser only that this product is free from defects in material and workmanship, and agrees to repair or replace, at Fast Flow's option, any submersible pump part found to be defective within 12 months from the date of purchase. This warranty is not transferable. This warranty does not cover damages resulting from shipping damage, improper installation, lack of service, incorrect power, or faulty severe service applications such as pumping abrasives, rocks, corrosives, or fluids in excess of 160°F. Warranty coverage is normally not available for wear parts such as: Pump Volute, Impellers, drive shaft, and hydraulic motor seals. Any modification or alteration of this equipment will void the warranty. Any claim for warranty damage must include photos of the defective part or parts, the serial number from the equipment, and a detailed description of the defect and possible causes. All warranty claims should be emailed to www.fastflowpump.com or mailed to our Moss Point MS address.

Submersible Pumps judged by Fast Flow Pumps to have been defective in workmanship or materials when shipped from the factory and within the warranty period will be either repaired or replaced at option free of charge excluding motor freight both ways, within the continental United States.

Fast Flow LLC Limited Warranty for Hydraulic Power Units. Fast Flow Pump warrants to the original purchaser that this product is free from defects in material and workmanship, and agrees to repair or replace, at our option, any part found to be defective within 12 months or 500 hours of use (whichever comes first) from the date of purchase. This warranty is not transferable. This warranty does not cover damages resulting from normal wear, abuse, careless handling, lack of service / proper preventative maintenance, improper fueling, improper application, and improper operation. Warranty coverage is not normally applied for items such as: Tires, belts, hoses, (fuel, oil, hydraulic oil) filters, batteries, and paint.

Fast Flow LLC does not warranty engines – warranty claims for engines must be handled through the engine distributor. Any modification or alteration of this equipment will void the warranty. Any claim for warranty damage must be accompanied by digital photos of the defective part or parts, the serial number from the equipment, and a detailed description of the defect and possible causes.

All warranty claims should contact Fast Flow Pumps at 9700 Hwy 63, Moss Point, MS 39562. Power Units judged by Fast Flow Pumps to have been defective in workmanship or materials when shipped from the factory and within the warranty period, will be either repaired or replaced at the discretion of Fast Flow Pumps free of charge excluding motor freight both ways.

Fast Flow Pumps shall not be liable for any damages, including consequential damages arising out of any breach of warranty and whether or not arising out of or based on Fast Flow's negligence, whether actual or implied, and for damages to any property or person arising out of the purchase or the use, operation or maintenance of the equipment. Fast Flow shall not be responsible for repairs or alterations made by others. No person is authorized to make any representations or warranties on behalf of Fast Flow Pumps and no other person is authorized to alter or extend any of the conditions contained in this warranty

EC Declaration of Conformity
In Accordance With
Machinery Directive 2006-44 EC, Annex II 1 A

10/01/2023
Moss Point, MS

Manufacturer

Fast Flow Pumps
9700 Hwy 63 North
Moss Point, MS 39562
228-475-2468

Technical File Curator

Jordan DuPre
9700 Hwy 63 North
Moss Point, MS 39562

FFP 3" Series, 4" Series, and 6" Series
Hydraulically driven submersible centrifugal pump

Declaration

Declaration is made that the above referenced products comply with all of the relevant health and safety provisions and referenced provisions of the Machinery Directive; and is also in compliance with the listed harmonized standards:

EN 890 Liquid Pumps,
EN ISO 20361 Operational Noise Level
EN ISO 13732-1 Hot Surfaces
EN ISO 9908 Class III Centrifugal Pumps
97/23/EC:1997 Pressure Equipment Directive

Declaration prepared by:

Tim Hoehn

Tim Hoehn, Lead Engineer, Fast Flow Pumps, LLC

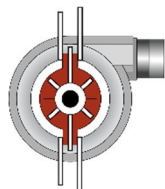

Fast Flow Pumps
9700 Hwy 63
Moss Point, MS, USA 39562
228.475.2468
www.fastflowpump.com